

The Clamp for sticky-Slides is an instrument to support the assembling of the ibidi sticky-Slides with a coverslip bottom. The assembled sticky-Slide is inserted into an adapter, which is then compressed between the brackets of the Clamp for sticky-Slides. The applied force is homogeneous on the overall area, to guarantee an optimal adhesive bond between the sticky-Slide and the coverslip (e.g. glass).

Material

The materials of the Clamp for sticky-Slides and the adapters are anodized aluminum and plastic. There are magnets integrated in both parts of the adapters to keep the two parts together.

The Clamp for sticky-Slides and the adapters are not autoclavable since they are temperature stable up to 60°C/140°F only. For sterilization we recommend cleaning all surfaces with an ethanol-soaked tissue.

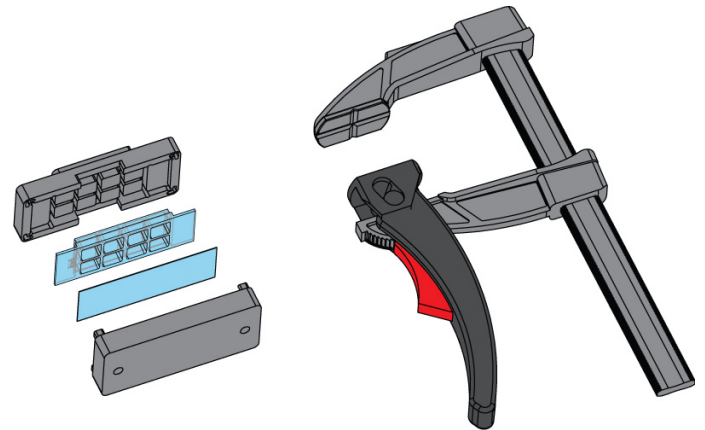

Specifications

The Clamp for sticky-Slides is available with adapters for several types of sticky-Slides. For detailed information about the handling of the sticky-Slides please refer to the [sticky-Slide instructions](#).

Specifications	
Clamping force	1.2 kN
Material	Anodized aluminium, plastic
Sterilization	Ethanol
Available adapters	
sticky-Slide 8 Well	
sticky-Slide I Luer	
sticky-Slide VI ^{0.4}	
sticky-Slide Chemotaxis ^{3D}	
Dimensions of Compatible Coverslip	
Width	75 mm
Length	25 mm
Thickness	0.1-1.0 mm

For optimal results please follow the proceeding of the protocol below:

1. Take the desired sticky-Slide out of the packaging and remove the protection film of the adhesive surface.
2. Bring the coverslip in position and glue it to the lower side of the sticky-Slide.

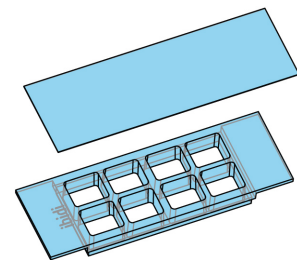

3. Put the assembled sticky-Slide in the adapter.

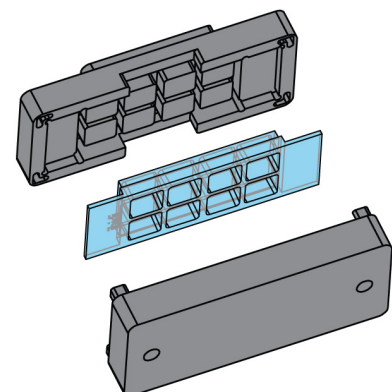

Handling of the Clamp for sticky-Slides

The working principle and the order of insertion of the parts of the Clamp for sticky-Slides is shown in the following picture:

Instructions

Clamp for sticky-Slides

4. Mount the adapter onto the upper bracket of the clamp.

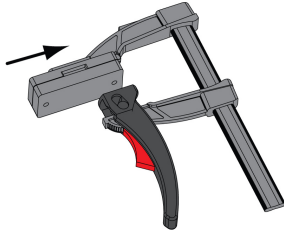

5. Move the lower bracket upwards until it pushes against the adapter. Make sure the lever is opened all the way.

6. Fix the adapter in the clamp by pulling tight the lever.

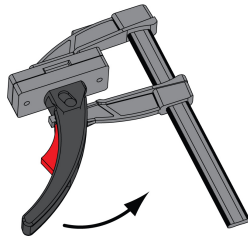

7. Keep the sticky-Slide pressed for approximately 30 seconds.

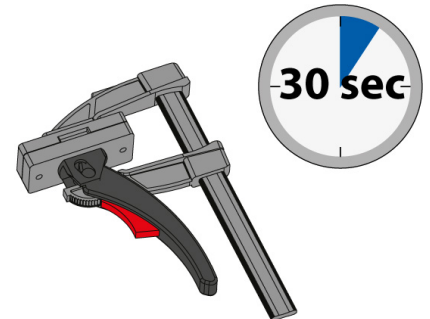

8. Open the clamp by pressing the red button and releasing the lever.

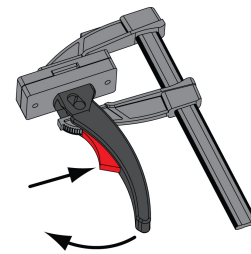

9. Remove the adapter from the clamp.

10. Open the adapter and remove the sticky-Slide.

Warnings:

- Always handle with care, because the glass coverslip might break during the procedure!
- Please take care not to trap your hand or fingers between the brackets!

Ordering Information

The Clamp for sticky-Slides is available with adapters for several types of sticky-Slides.

Cat. No.	Description	Characteristics
80040	Clamp for sticky-Slides:	unsterile
80041	Adapter for sticky-Slide 8 Well:	unsterile
80042	Adapter for sticky-Slide I Luer:	unsterile
80043	Adapter for sticky-Slide VI^{0.4}:	unsterile
80044	Adapter for sticky-Slide Chemotaxis^{3D}:	unsterile

For research use only!

Further technical specifications can be found at www.ibidi.com. For questions and suggestions please contact us by e-mail info@ibidi.de or by telephone +49 (0)89/520 4617 0. All products are developed and produced in Germany.

© ibidi GmbH, Am Klopferspitz 19, 82152 Martinsried, Germany.