

The ibidi product family is comprised of a variety of μ-Slides and μ-Dishes, which have all been designed for high-end microscopic analysis of fixed or living cells. The high optical quality of the material is similar to that of glass, so you can perform all kinds of fluorescence experiments with uncompromised resolution and choice of wavelength.

The μ-Plate 96 Well allows you to perform high resolution microscopy in a standard multi-well format. For less well-to-well crosstalk in fluorescence microscopy this imaging plate is made out of a black plastic material.

Material

ibidi μ-Slides, μ-Dishes, and μ-Plates are made of a plastic that has the highest optical quality. The polymer coverslip on the bottom exhibits extremely low birefringence and autofluorescence, similar to that of glass. Also, it is not possible to detach the bottom from the upper part. The μ-Slides, μ-Dishes, and μ-Plates are not autoclavable, since they are only temperature-stable up to 80°C/175°F. Please note that gas exchange between the medium and incubator's atmosphere occurs partially through the polymer coverslip, which should not be covered.

Optical Properties ibidi Polymer Coverslip

Refractive index n_D (589 nm)	1.52
Abbe number	56
Thickness	No. 1.5 (180 μm)
Material	polymer coverslip

Please note! The ibidi Polymer Coverslip is compatible with certain types of immersion oil only. A list of suitable oils can be found on page 3.

Shipping and Storage

The μ-Slides, μ-Dishes and μ-Plates are sterilized and welded in a gas-permeable packaging. The shelf life under proper storage conditions (in a dry place, no direct sunlight) is listed in the following table.

Conditions

Shipping conditions	Ambient
Storage conditions	RT (15-25°C)

Shelf Life

ibiTreat, Uncoated	36 months
--------------------	-----------

Geometry

The μ-Plate 96 Well provides standard geometry and numbering (A-H, 1-12). The bottom of the μ-Plate 96 Well provides a high accuracy.

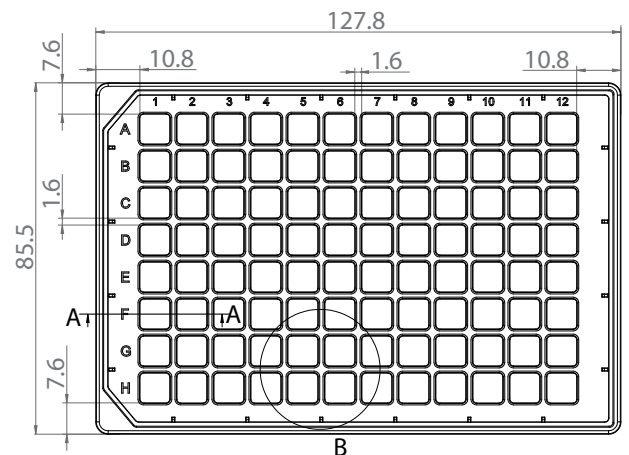

The μ-Plate 96 Well meets all important values of the ANSI/SBS Standards (1-2004, 2-2004, 3-2004 and 4-2004).

Dimensions of the μ-Plate 96 Well in mm

Length	127.8	± 0.2
Width	85.5	± 0.2
Height with lid	17.2	± 0.4
Height without lid	15.0	± 0.4
Well to well distance	9.0	± 0.1
Well clearance	0.8	± 0.1

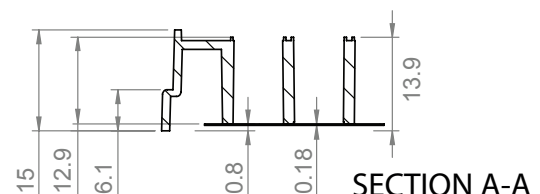

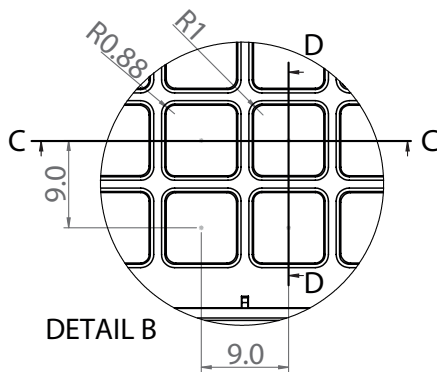

Surface

The μ-Plate 96 Well is available with ibiTreat and uncoated surface. The ibiTreat surface is a physical treatment and optimized for adhesion of most cell types. Many cell lines as well as primary cells were tested.

A specific coating of the μ-Plate 96 Well can be done yourself following the procedure in the section Coating Your μ-Plate 96 Well.

Coating Your μ-Plate 96 Well

The uncoated μ-Plate 96 Well must be coated to promote cell adhesion. If you like to establish a certain coating for your demands we recommend testing your coating procedure on uncoated and ibiTreat μ-Plate 96 Well, since we have observed that some biomolecules adhere differently to hydrophobic or hydrophilic plastic surfaces.

- Prepare your coating solution according to the manufacturer's specifications or reference.
- Apply 300 μl in each well. The coating area using 300 μl is 2.35 cm².
- Follow your coating protocol.

Further information about coatings are provided in [Application Note 08 "Cell culture coating"](#).

Remove the Protection Film Before Usage

The bottom of the μ-Plate 96 Well is covered with a film to protect the optical quality of the plastic surface. Please pull off the protection film before usage!

Seeding Cells

- Trypsinize and count cells as usual. Dilute the cell suspension to the desired concentration. Depending on your cell type, application of a $2-5 \times 10^4$ cells/ml suspension should result in a confluent layer within 2-3 days.
- Apply 300 μl cell suspension into each single well. Avoid shaking as this will result in inhomogeneous distribution of the cells.
- Cover the μ-Plate 96 Well with the supplied lid. Incubate at 37°C and 5% CO₂ as usual.

Single Well Parameters of the μ-Plate 96 Well

Single well dimensions	7.4 × 7.4 ± 0.15 mm
Single well depth	12.9 ± 0.2 mm
Volume	300 μl
Growth area	0.56 cm ²
Coating area using 300 μl	2.35 cm ²

Accuracy of the μ-Plate 96 Well Bottom

Inner well flatness	± 5 μm
Whole plate flatness	± 25 μm
Bottom matches coverslip	No. 1.5

For manufacturing process reasons, the well wall angles differ slightly. The details are shown in the graphics below.

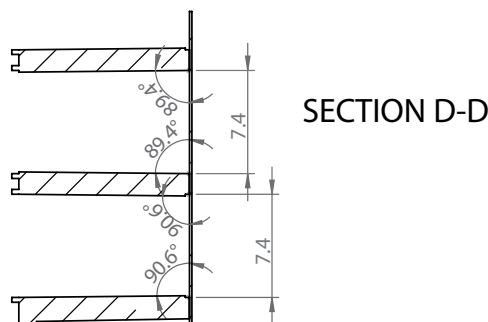
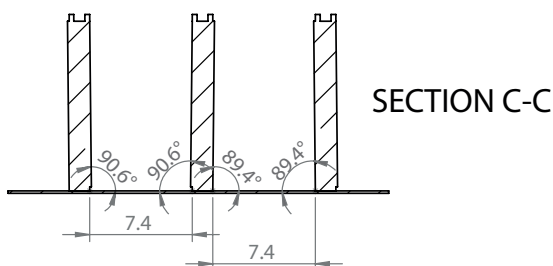

Tip:

We recommend not to fill more than 600 μl into the μ-Plate 96 Well in order to avoid liquid contacting the lid.

Undemanding cells can be left in their seeding medium for several days and grow to confluence there. However, best results might be achieved when the medium is changed every 2–3 days. Carefully aspirate the old medium and replace it by 300 μl fresh medium.

Tip:

You can stack the μ-Plates to save space in you incubator. This will not affect cell growth. We recommend making batches with up to 6 plates, due to stability reasons.

Cell Microscopy and Solvents for Fixation

To analyze your cells, no special preparations are necessary. Cells can be observed live, or fixed directly in the μ-Plate 96 Well, preferably on an inverted microscope. Due to the thin bottom, high resolution microscopy is possible. The material is compatible to most fixatives, like acidic acid, alcohols and PFA. For a full list of compatible solvents and more information on chemical compatibility, please visit the FAQ section on www.ibidi.com. For optimal results in fluorescence microscopy and storage of stained probes ibidi provides a mounting medium (50001) optimized for μ-Dishes and μ-Slides.

Immersion Oil

When using oil immersion objectives with the ibidi Polymer Coverslip, use only the immersion oils specified in the table below. The use of any non-recommended oil could damage the ibidi Polymer Coverslip. The resulting leakage may harm objectives and microscope components. All immersion oils that are not listed in the table below should be considered as non-compatible.

Company	Product	Ordering No.	Lot Number	Test Date
ibidi	ibidi Immersion Oil	50101	16-12-27	01/2017
Zeiss	Immersionol 518 F	444960	160706	01/2017
Zeiss	Immersionol W 2010	444969	101122	04/2012
Leica	Immersion Liquid	11513859	n.a.	03/2011
Cargille	Type A	16482	100592	01/2017
Cargille	Type HF	16245	92192	01/2017
Olympus	Silicone Immersion Oil	SIL300CS-30CC	N4190800	01/2017
Carl Roth	Immersion oil	X899.1	414220338	01/2017

Ordering Information

The ibidi μ-Plates are available with the following surfaces.

μ-Plate 24 Well

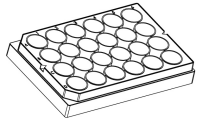

Cat. No.	Description
82406	μ-Plate 24 Well ibiTreat: #1.5 polymer coverslip, tissue culture treated, sterilized
82401	μ-Plate 24 Well Uncoated: #1.5 polymer coverslip, hydrophobic, sterilized

μ-Plate 96 Well

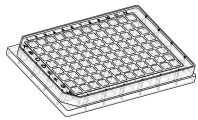

Cat. No.	Description
89626	μ-Plate 96 Well ibiTreat: #1.5 polymer coverslip, tissue culture treated, sterilized
89621	μ-Plate 96 Well Uncoated: #1.5 polymer coverslip, hydrophobic, sterilized

For research use only!

Further technical specifications can be found at www.ibidi.com. For questions and suggestions please contact us by e-mail info@ibidi.de or by telephone +49 (0)89/520 4617 0. All products are developed and produced in Germany.
© ibidi GmbH, Am Klopferspitz 19, 82152 Martinsried, Germany.